

# The new endless winch

# Yale Mtrac

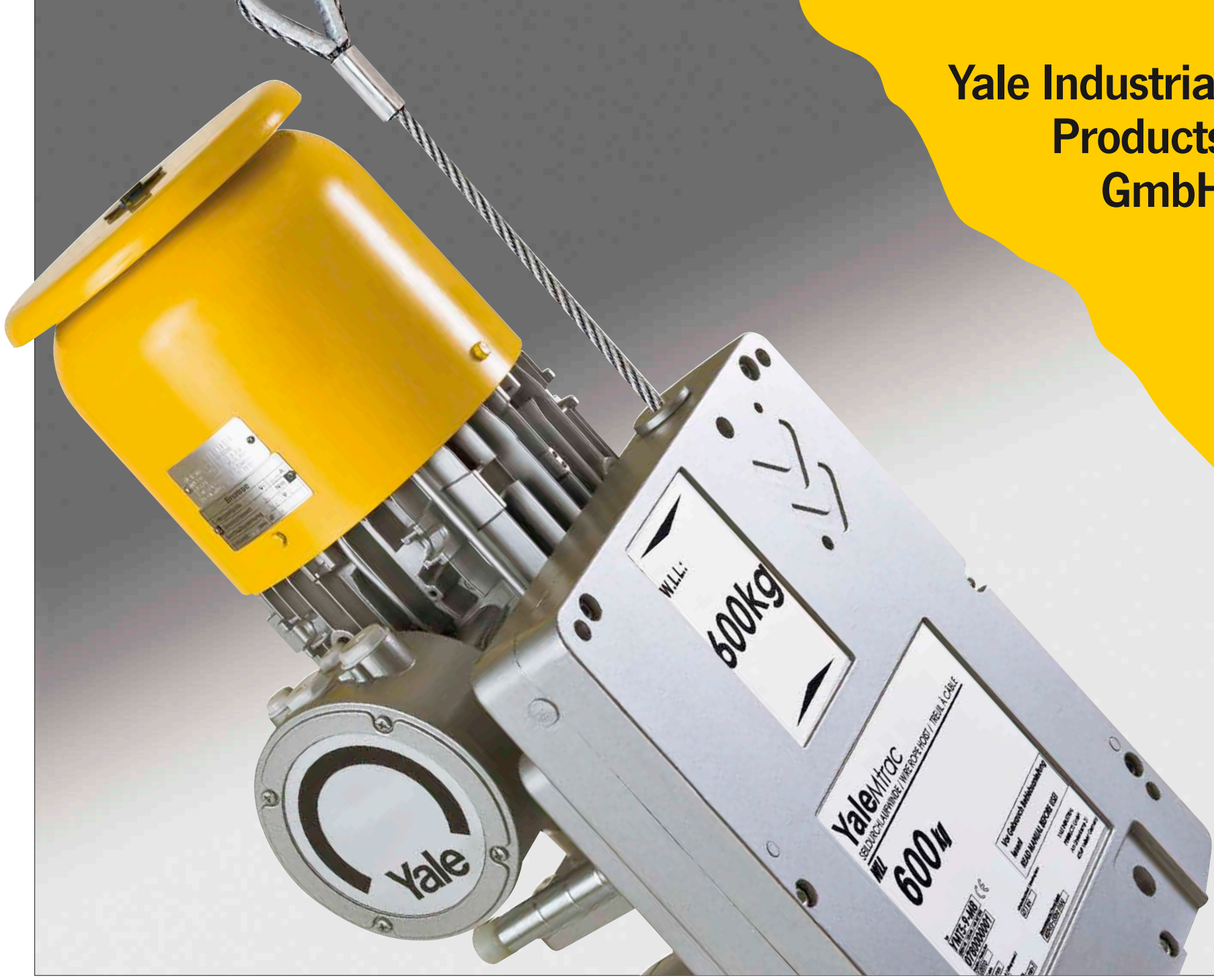

Yale Industrial  
Products  
GmbH

# Yale

- 1877 Yale designs the first spur geared hand chain hoist incorporating the Weston screw-and-disc type load brake. The design principle is used today for almost all hand chain hoists.
- 1936 Start of hoist manufacture in Velbert with production of the world renowned Yale Pul-Lift® ratchet lever hoist. This robust and reliable tool was (and still is) the key product establishing Yale's reputation in hoisting technology in Europe and abroad. To date more than one million Yale Pul-Lift® units have been manufactured at the Velbert plant.
- 1985 A new era began with the formation of Yale Industrial Products GmbH. By continuous and innovative product development and expanding the international network through Yale sales organisations and distributors Yale Industrial Products GmbH has gained a leading position for hoisting equipment.
- 2002 Yale presents the Yalelift 360. Areas of operation as well as operator conditions have been improved considerably. Innovative thinking and design give additional flexibility, the operator is no longer forced to work in the danger zone near the load.
- 2008 Yale starts production for the new electric chain hoist model YaleVego (CPV).
- 2009 Yale presents the electric wire rope hoist model YGK and expands its product range to wire rope hoists with capacities up to 15 t.
- 2010 Yale introduces the product-line of spring balancers, series YBF and YBA.  
The product portfolio is supplemented by endless winches for material transport and passenger elevation.



## The advantages at a glance

### Easy to assemble –

Industrial plug connections allow convenient connection to existing electrical equipment.

### Versatile applications –

Since the rope is not collected, the compact winch is light and easy to handle. Variable connection possibilities allow simple attachment in a wide range of positions.

### Endless –

The unlimited rope length makes unrestricted lifting heights and traction lengths possible.

### Ready for use –

The integrated CE-contractor allows a quick set-up of operation.

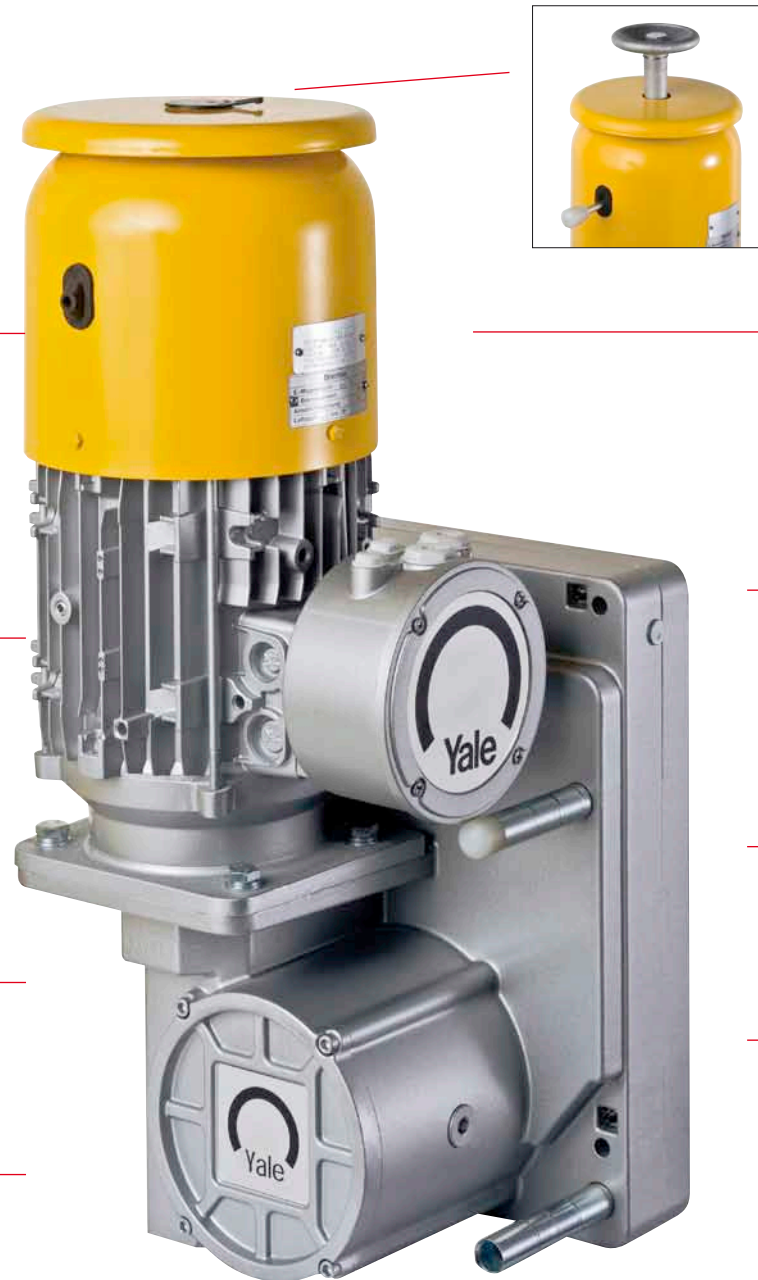

### Safety hand wheel –

In an emergency (power failure), upward movement with released brake is possible by means of the hand wheel included in the supply (standard delivery scope only for winches for passenger elevation application).

### Long service life –

Drive sheave and pressure rollers of special nitrided steel with a surface hardness of approx. 70 HRC guarantee low wear of the components.

### High reliability –

The fully-synthetic special oil ensures highest possible efficiency for quiet running characteristics, in a temperature range of -40° up to 70° C.

### Easy to service –

Standardised components feature easy access to all wearing parts.

### Quality engineering –

The robust, precisely machined housing of die-cast aluminium ensures a low deadweight and outstanding rigidity.



## Features of the endless winch



### Safety lowering mechanism

In the event of a power failure, the electro-mechanical brake can be released manually in order to ensure safe and controlled lowering of the load.

Safe lowering is guaranteed by the integrated centrifugal force brake.



### Hoist motor & brake

Special motor with classification 1 Bm/M3 (1 Cm/M2 for 18 m/min) according to FEM/ISO 4301-1. Protected to IP 55.

Low maintenance electro-mechanical brake, no readjustment necessary.



### Flexible attachment points

The winch can be suspended from a central suspension point by means of a load pin.

As an alternative, attachment points in the corners of the housing are available for flexible attachment of the winch with screws or pins.

### Contactor control for material transport applications (stationary application)

- Control cabinet (260 x 124 x 95 mm)
- Protected to IP 55 (acc. to EN 60 529)
- Temperature range -20° C up to +40° C
- Increased operating safety through 42V control voltage
- Master control relay/emergency stop contactor as standard for a high degree of safety
- Easily accessible strip terminal
- Cable entry point by cable sleeves
- Motor connected with control cable

### Control cabinet for material transport applications (mobile application)

- Control cabinet (300 x 400 x 150 mm)
- Protected to IP 55 (acc. to EN 60 529)
- Temperature range -20° C up to +40° C
- Increased operating safety through 24V control voltage
- Master control relay/emergency stop contactor as standard for a high degree of safety
- Phase-sequence relay for monitoring the direction of rotation
- Control transformer according to EN 61558-2, input and output separately fused
- Warning buzzer for signalling an overload
- Easily accessible strip terminal
- Cable entry point by screwed cable glands
- Motor connected with connector plug
- Power supply connection with phase-changing switch
- Connection for UP emergency limit switch provided



## Safety for passenger elevation

In accordance with the requirements of DIN EN1808, each winch used for passenger elevation must feature a safety system on an independent safety rope. Yale offers two different safety catching devices for two common applications.

Both types have been approved for passenger elevation and comply with standard DIN EN1808 "Safety requirements on suspended access equipment".

In addition, the catching devices have been certified by an independent inspection institute (DGUV).



### Overspeed safety catching device (YOSL)

This overspeed catching device is automatically tripped when the lowering speed exceeds 30 m/min (0.5 m/s).

The integrated clamping jaw mechanism of hardened steel stops the lowering movement of the system within a few centimetres.



### Inclined position safety catching device (YISL)

This inclined position catching device is automatically tripped when the angle of the rope or the platform exceeds 5°.

The integrated clamping jaw mechanism holds the rope and immediately stops the movement of the system.

- Robust sheet-steel enclosure
- Clamping mechanism of hardened steel
- Attachment with two screws (M12) or load pins (12 mm)

## Control cabinet for passenger elevation applications

- Control cabinet (300 x 400 x 150 mm)
- Protected to IP55 (acc. to EN 60 529)
- Temperature range -20° C up to +40° C
- Increased operating safety through 24 V control voltage
- Master control relay/emergency stop contactor as standard for a high degree of safety
- Phase-sequence relay for monitoring the direction of rotation
- Control transformer according to EN 61558-2, input and output separately fused
- Warning buzzer for signalling an overload
- Easily accessible strip terminal
- Cable entry point by screwed cable glands
- Motor connected with connector plug
- Power supply connection with phase-changing switch

## Optional

- Control cabinet for synchronous control of two winches
- Supporting feet and arms for fixing the control cabinet

**! Certified for passenger elevation applications in accordance with DIN EN 60204-32 by an independent inspection institute (DGUV).**



### Control cabinet with integrated voltage protection

Features are equal to those enumerated under control cabinet for passenger elevation applications, additionally:

- Emergency-stop and UP/DOWN buttons on front door of control cabinet for controlling the winch (pendant control as an option)
- Main switch to turn off the current for the whole system for assembly and maintenance purposes
- Main fuse, fault current circuit breaker and motor circuit breaker included

## Features

### Features

- Robust and rigid housing of die-cast aluminium
- Gearing and drive sheave of hardened steel
- Limit switch for lifting force as standard (only for winches for passenger elevation)
- Universal attachment of the winches by means of central 16 mm load pin or two M10 screws
- Group of mechanisms 1 Bm/M3 (1 Cm/M2 for 18 m/min) according to FEM
- All motors protected to IP 55 as standard
- Standard operating voltage: Euro voltage 400V, 3-phases, 50 Hz alternatively 460V, 3-phases, 60 Hz
- 24V control voltage (except material transport control, stationary application – 42V)
- Phase monitoring (except material transport control, stationary application)
- Hoist motor with thermal overload protection
- Certified by an independent inspection institute (DGUV).
- Certified for passenger elevation applications in accordance with DIN EN 14492-1 by an independent inspection institute (DGUV).

### Options

- Other operating voltages
- Double control for several winches
- Radio remote control
- Limit switch for upward travel
- Counters for operating hours and number of starts
- Catching devices (overspeed or inclined position tripping, required for passenger elevation applications)
- Adaptor for fitting with shackle
- Ropes for endless winches and catching device
- Overload cut-out (included in the scope of supply for passenger elevation winches)

## Technical data model Mtrac Winches for material transport

Model	EAN-No. 4025092* for stationary application**	EAN-No. 4025092* for mobile application***	Capacity  kg	Lifting speed  m/min	Nominal rope diameter  mm	Motor  kW	Weight for stationary application**  kg	Weight for mobile application***  kg
YMT 5-9-M8	*668569	*668644	500	9	8.4	1.1	54	62
YMT 5-18-M8	*668576	*668651	500	18	8.4	2.0	54	62
YMT 6-9-M8	*668583	*668668	600	9	8.4	1.1	55	63
YMT 6-18-M8	*668590	*668675	600	18	8.4	2.0	55	63
YMT 8-9-M8	*668606	*668682	800	9	8.4	1.8	55	63
YMT 8-18-M8	*668613	*668699	800	18	8.4	3.6	56	64
YMT 10-9-M9	*668620	*668712	980	9	9.0	1.8	55	63
YMT 10-18-M9	*668637	*668705	980	18	9.0	3.6	56	64

\*\*incl. control voltage 400V, 3 Ph, 50 Hz, directly attached to the winch, pendant control with emergency-stop (length of control cable 3 m)

\*\*\*incl. control cabinet with integrated CE-connector, pendant control with emergency-stop (length of control cable 3 m)

## Dimensions Model YaleMtrac

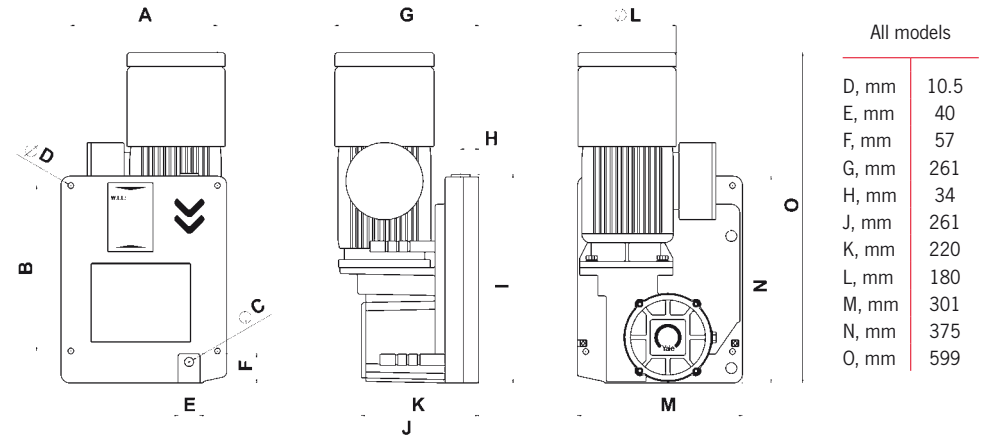

## Technical data model Mtrac Winches for passenger elevation acc. to EN 1808

Model	EAN-No. 4025092*	Capacity kg	Lifting speed m/min	Nominal rope diameter mm	Motor kW	Weight without rope incl. control cabinet kg
YMT 5-9-P8	*668729	500	9	8.4	1.1	72
YMT 5-18-P8	*668736	500	18	8.4	2.0	72
YMT 6-9-P8	*668743	600	9	8.4	1.1	73
YMT 6-18-P8	*668750	600	18	8.4	2.0	73
YMT 8-9-P9	*668767	800	9	9.0	1.8	73
YMT 8-18-P9	*668774	800	18	9.0	3.6	74
YMT 10-9-P10	*668781	1000	9	10.2	1.8	73
YMT 10-18-P10	*668798	1000	18	10.2	3.6	74

Incl. control cabinet with integrated CE-connector  
 Option: Emergency-stop and UP/DOWN buttons on control cabinet for controlling the winch,  
 pendant control with emergency-stop (length of control cable 3 m)

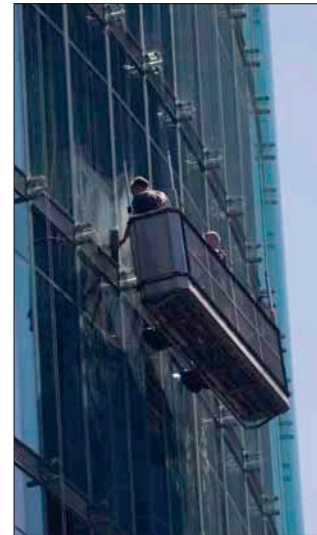

## Dimensions overspeed safety catching device (YOSL)

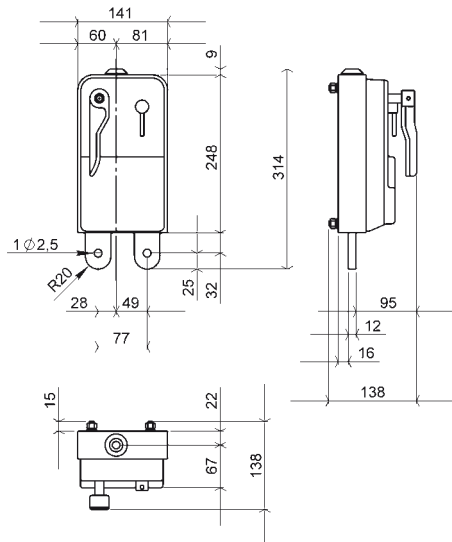

Model	EAN-No. 4025092*	Capacity kg	for- rope diameter mm
YOSL6-8	*582803	500	8.4
YOSL6-8	*582803	600	8.4
YOSL8-9	*582742	800	9.0
YOSL10-10	*582766	1000	10.2

## Dimensions inclined position safety catching device (YISL)

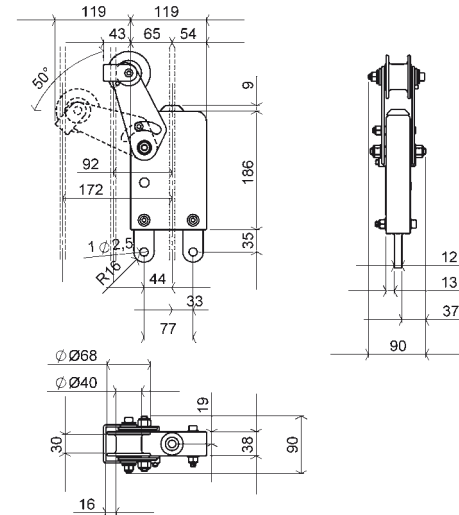

Model	EAN-No. 4025092*	Capacity kg	for- rope diameter mm
YISL5-8	*582827	500	8.4
YISL6-8	*582827	600	8.4
YISL8-9	*582759	800	9.0
YISL10-10	*582797	1000	10.2

The comprehensive  
Yale product range  
also offers:



#### Crane System

- Wall-mounted jib cranes
- Floor-mounted jib cranes
- Gantry cranes
- Workshop cranes

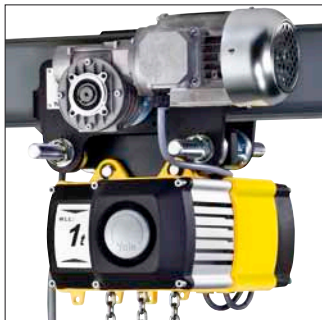

#### Hoisting Equipment

- Electric chain hoists
- Pneumatic chain hoists



#### Textile lifting slings

- Webbing slings
- Round slings
- Round sling assembly

#### Lashing Equipment

- Lashings
- Special lashings
- Lashing equipment

Request our catalogue  
or visit our homepage  
on the Internet: [www.yale.de](http://www.yale.de)



Certified since November 1991

Yale Industrial Products GmbH  
Am Lindenkamp 31 · D-42549 Velbert

Phone: 00 49 (0) 20 51/600-0  
Fax: 00 49 (0) 20 51/600-127  
Web Site: [www.yale.de](http://www.yale.de) · e-mail: [central@yale.de](mailto:central@yale.de)

We reserve the right to change product specifications without prior warning. We accept no responsibility for printing or typing errors. Effective from September 2010.

Reproduction or reprinting of this brochure only with written permission of Yale Industrial Products GmbH.